

Mercury Max Series Engines



LP311EG13

LP311EG13 Engine

fixed speeds
1500 r/min

11 - 12 kWm | 14.8 – 16.1 bhp²

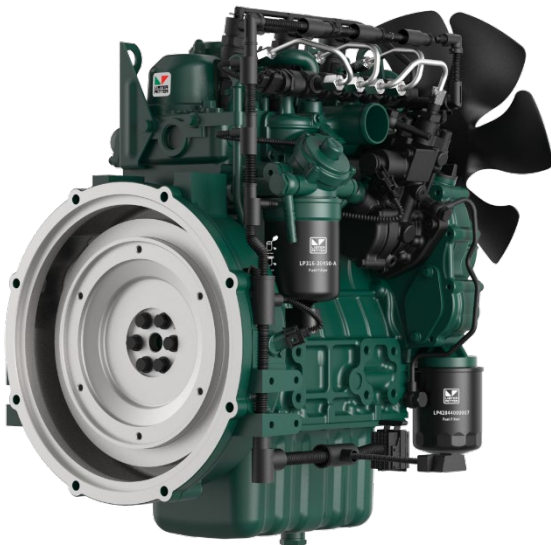

OVER VIEW

The engine is specifically designed as a Power generating engine suitable for use in Stage III emissions territories. It is durable, reliable and easy to maintain with oil & filter changes up to 500 hours, dependant on operational conditions. It is designed for continuous operation in ambient temperatures up to 52°C (125°F) and a cold start capability down to -25°C (-13°F).

G Build

Note:

For further information and approval please contact Applications Department

* Optional items standard on most builds.

BASIC ENGINE CHARACTERISTICS

- direct fuel injection
- 3 cylinders
- liquid cooled
- natural aspirated

DESIGN FEATURES AND EQUIPMENT

- electric starting
- anti clockwise rotation, looking on the flywheel end
- SAE Flywheel connection
- SAE compliant flywheel housing
- radiator and fan guard
- cast-iron structural crankcase
- self-vent fuel injection system
- HPCR fuel injection equipment
- ECU governing
- flywheel and gear ring
- cyclonic heavy duty airfiltration
- oil pressure protection switch
- coolant temperature protection switch
- spin-on full flow lubricating oil filter
- fuel filter / agglomerator
- intake and exhaust manifolds
- operators' handbook

OPTIONAL ITEMS

A range of options are available that allows you to select a specification that matches your requirements; please consult your Lister Petter Engine distributor.

POWER OUTPUTS³ | Stage III EMISSIONS RATINGS

Model	Speed, r/min	Power	Gross ²		Net		Standard Generator Output*		
			kW	bhp	kW	bhp	Power	kVA	kWe
LP311EG13	1500	Continuous	11	14.8	10.5	14.1	PRP	10	8
		Fuel Stop	12	16.1	11.5	15.4	ESP	11	8.8

TECHNICAL DATA

Engine fixed speed 1500r/min	LP311EG13	
Type of fuel injection	Direct	
Number of cylinders	3	
Aspiration	Natural	
Direction of rotation (flywheel end)	Anti clockwise	
Nominal cylinder bore	mm	78
	in	3.1
Stroke	mm	78.4
	in	3.1
Total cylinder capacity	litre	1.1
	in ³	67.1
Compression ratio	18.0:1	
Firing order (number 1 cylinder is at the gear end)	1-3-2	
Alternator	12V×35A	
Starter motor	12V×1.4kW	
Fuel injection pump	HPCR fuel injection	
Speed governor	ECU	
Speed regulation class	ISO 8528 G3	
Fly wheel housing	SAE 5	
Fly wheel	SAE J620 Size 6.5"	

RATING DEFINITIONS TO ISO 3046

ISO Standard Conditions

Barometric pressure 100kPa
 Relative humidity 30%
 Ambient air temperature at the inlet manifold 25°C

Power Standards

The engine performance corresponds to ISO 3046, BS 5514 and DIN 6271. The technical data applies to an engine without cooling fan and operating on a fuel with calorific value of 42.7 MJ/kg (18360 BTU/lb) and a density of 0.84 kg/liter (7.01 lb/US gal, 8.42 lb/Imp gal).

Fixed Speed: Continuous Power (ICN)

The power in kW which the engine is capable of delivering continuously at the stated crankshaft speed, under ISO 3046 standard conditions, measured at the flywheel without power-absorbing accessories, provided that the engine is overhauled and maintained in good operating condition and that fuel to BS EN 590 Class A1 or A2, and lubricating oils to the correct performance specification and viscosity classification as recommended by Lister Petter Engine Company are used.

Fixed Speed (Fuel Stop): Overload Power (ICXN)

The maximum power in kW which the engine is capable of delivering intermittently at the stated crankshaft speed for a period not exceeding one hour in any period of twelve hours of continuous running, immediately after working at the continuous power, under ISO 3046 standard conditions and with the provisions specified for continuous power in item (1) above, but with the fuel limited so that the fuel stop power cannot be exceeded.

Derating

For non-standard site conditions, reference should be made to relevant BS, ISO & DIN standards.

Notes:

1. Power ratings are measured at the flywheel end.
- 2.. Power ratings and fuel consumption figures apply to a fully run-in, non derated engine without a radiator and fan fitted, and without power absorbing accessories or transmission equipment.

* The power output of the generator data is calculated using a typical efficiency of the AC generator. The kVA and kWe values are converted as per standard power factor 0.8. Generator data is for reference only.

EXHAUST AND INTAKE SYSTEM | 1500 RPM FIXED SPEED ENGINES

Parameter	Engine Model
	LP311EG13
EXHAUST	
Maximum allowable back-pressure (kPa)	≤ 7.2
Exhaust gas flow, (m ³ /min)	1.8
Emissions level	EURO V
Exhaust gas temperature, continuous (°C)	320
Exhaust gas temperature, overload (°C)	350
Exhaust pipe diameter - recommended	63mm
INTAKE	
Maximum allowable inlet restriction (kPa)	≤ 3
Combustion air flow(m ³ /min)	0.9

ENGINE COOLANT SYSTEM | 1500 RPM, FIXED SPEED

Parameter	Engine Model
	LP311EG13
Cooling method	Liquid cooled (belt driven water pump)
RADIATOR	
Material	Aluminium
Radiator face area (m ²)	6
Pressure cap setting (kPa)	90
FAN	
Diameter (mm)	420
Number of blades	5
Material	Plastic
Type	Blower type
COOLANT	
Cooling package maximum operating temperature (°C)	≤104
Total system with radiator capacity (L)	6
Total system without radiator capacity (L)	1.8
Thermostat type	Wax Capsule
Thermostat opens at... (°C)	82
Thermostat fully open at... (°C)	≤ 95
Minimum temperature to engine (°C)	-25
Maximum static pressure head at pump (meters at 1500rpm)	14
Cooling fan flow rate (l/s)	15

Recommended coolant:

50% ethylene glycol with a corrosion inhibitor (BS 6580 : 1992 or ASTM D3306-89 or AS2108) and 50% de-ionised water

ENGINE LUBRICATION SYSTEM

Parameter	Engine Model
	LP311EG13
Lubricating method	Pressure feed and splash
Sump capacity including filter (L)	4.5
Service Interval (hr)	500
Oil filter type	Spin-on full flow oil filter
Oil Specification	API CH-4
	ACEA E5
Oil consumption % SFC	≤ 0.1%
Oil consumption, 100% (l/hr)	0.006
Lubricating oil temperature (°C)	90-105
Maximum oil temperature (°C)	108
Maximum operation angle of engine (degrees)	10°

APPROXIMATE FUEL CONSUMPTION

		Engine model	
Speed, r/min	Load	LP311EG13	
		g/kWh	l/h
1500	110%	240	3.48
	100%	238	3.13
	75%	233	2.30
	50%	246	1.62
	25%	295	0.97

*Diesel fuel density 0.835 g/ cm³

* The power output of the engine is calculated according to NPT conditions.

* For non-standard site conditions not listed, reference should be made to BS, ISO and DIN standards.

* Inquiry should always be made to the technical department of the respective manufacturer if the attitude is above 3000m.

ENGINE NOISE LEVELS

Parameter	Engine Model
	LP311EG13
Sound pressure level at 1m	≤95 dB(A)

APPROXIMATE DIMENSIONS AND WEIGHT

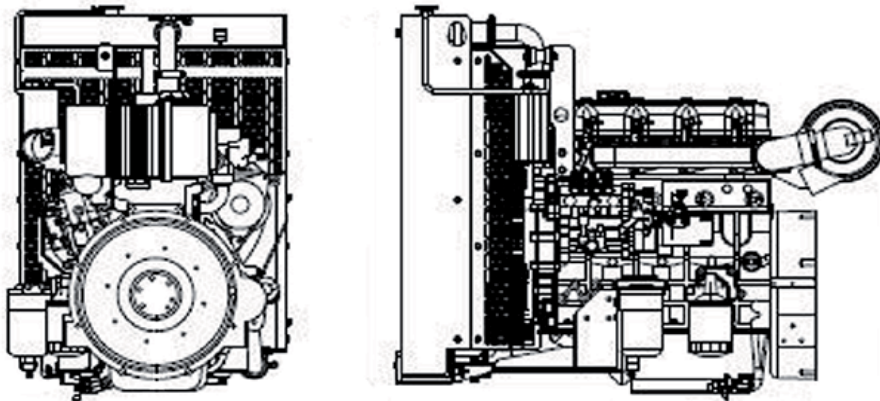

Engine model		LP311EG13
Dry weight	kg	130
	lb	286
Length (A)	mm	810
	in	31.6
Width (B)	mm	470
	in	18.3
Height (C)	mm	708
	in	27.6



Head Office
Lister Petter Engine Company Limited

Rutland House, Minerva Business Park,
Lynch Wood, Peterborough, PE2 6PZ.

Distributor Address



enquiry@listerpetter.com
www.listerpetter.com